

OTHER COMPONENTS



Silicon hose Coupler and anti-syphone valve Ceiling rosette Cable tie, double-sided stickers Screws and wall plugs

PRODUCT SPECIFICATIONS

Section	Specification	Section	Specification
Capacity of AC	Up to 16kw / 54,000Btu/h	Available fluid	Condensate of 1~40°C
Power supply	220V 50/60Hz 120V 50/60Hz	Dry running	Not allowed
Power consumption	2.5W	Intermittant rating	3 minutes
Max discharge head	8m	Safety switch	Max 3 amp
Max flow rate	33L/h at zero meter	Pump size (mm)	106(W) x 52(H) x 950(L)
Outlet size	¼" (6mm)	Weight	1.2kg

WARRANTY

The WHISPA-Q condensate pump comes with a 2-year (24 months) warranty. This warranty covers all parts with material or manufacturing faults.

The buyer's only remedy is the replacement or repair of the defective parts. In no case can labour costs and any consequential damage be cited as a basis for a complaint. Any returned units must be complete and must be accompanied by a written list of the defects identified.

We are unable to accept any liability in case of non-conforming installation or non-compliance with the specifications or maintenance recommendations that have been stated.

Warranty will be void if any of the following conditions are found:

1. Sealed motor housing has been opened.
2. Product has been connected to a voltage not specified on the product.
3. The power cord has been cut to length less than three feet.
4. The pump has been allowed to operate dry.
5. The pump has been used to circulate anything other than water at room temperature.
6. Any other form of product abuse by the customer

- * Acceptable for indoor use only
- * Nonsubmersible pump

DISCLAIMER

The foregoing warranty is an exclusive warranty in lieu of any other express warranties. Any implied warranties (including but not limited to any implied warranty of merchantability or fitness for a particular purpose) to the extent either applies to a pump shall be limited in duration to the periods of the express warranties given above.

WHISPA-Q-TRUNK



PUMPS
WHISPA-Q
Ultra Quiet Pump in Trunking

Pump House
Glaisdale Drive East, NG8 4LY
Nottingham United Kingdom
Email sales@pumph.co.uk
Phone +44(0)115 900 5858
Made in Korea

PUMP
HOUSE
DIVERSiTECH
company

Ultra Quiet Pump in Trunking

PUMPS
WHISPA-Q
Ultra Quiet Pump in Trunking

USER INSTRUCTION MANUAL

Patented Technology



- Innovative design
- Ultra quiet
- Low power consumption

FUNCTION OF THE PRODUCT

WHISPA-Q condensate removal pump is designed to remove condensate from air conditioners automatically.

NAME OF EACH PART

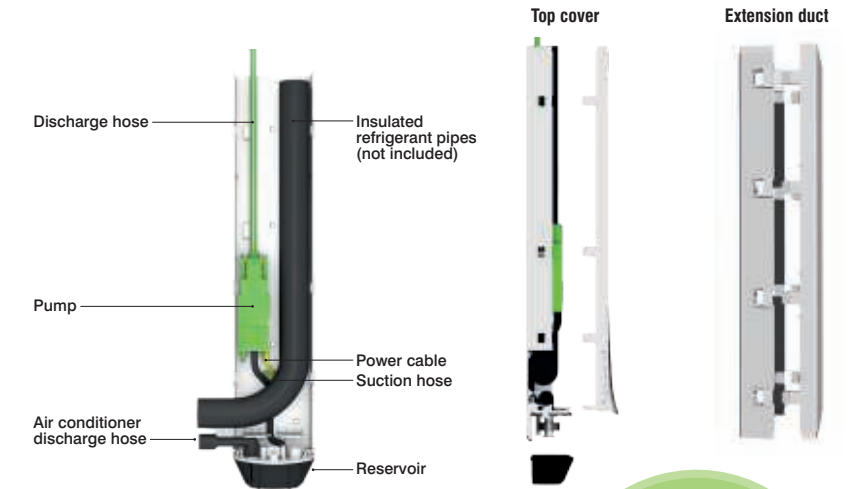

70%
LESS
energy

CAUTION

We are not responsible for any water leaks or damage caused by use of a hose that is not one of our recommended products.

Please read carefully, the **User Instruction Manual** before installation, operation and maintenance of this equipment.

WHISPA-Q

PUMP
HOUSE
DIVERSiTECH
company

DESCRIPTION OF THE SENSOR PART

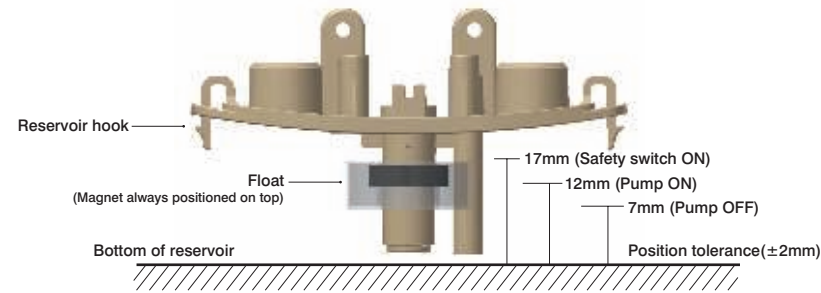

FLOW RATES AT EACH HEAD

Head	0m	4m	6m	8m
Rate of flow (L/h)	33	25	21	16

HOW TO INSTALL THE PRODUCT

- Select location on the left or right side of the wall-mount air conditioner.

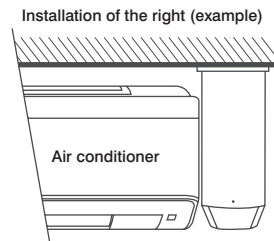
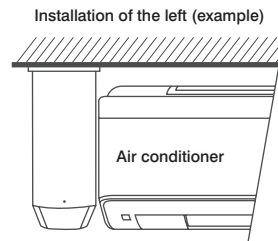

- Cut out the upper part of the pump to fit the installation space. In the event the length needs to be extended, connect the duct afterwards.

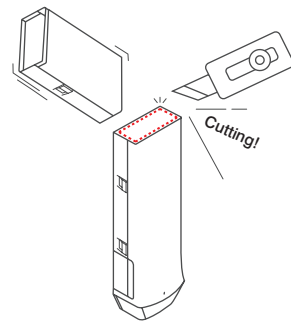

- Remove the 'knock-out' opening next to the air conditioning unit using a cutter.

Ensure that there are no sharp areas left on the trim area.

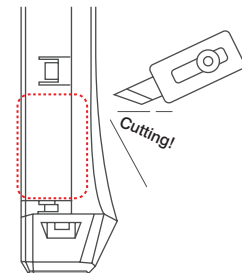

- Mark holes on the wall as per the locations on the rear section of trunking and fix using appropriate screws.

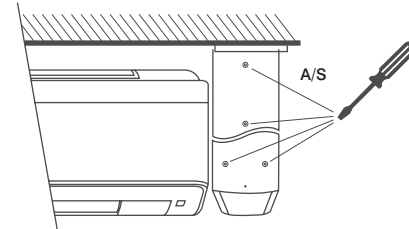

- Connect the "7"-shaped air conditioner discharge hose of the pump to the drain hose of the air conditioning unit with the coupler.

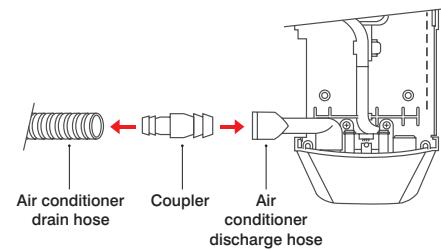

Take care not to bend or kink the hose connecting pump to the reservoir.

- High level float wiring (optional)**

- The high level float wiring can be used to interrupt the signal to the A/C unit in the event of blockage to prevent water leakage. See wiring diagram.

Please check the A/C manufacturers wiring for compatibility of wiring to either the temperature sensor line or control circuit.

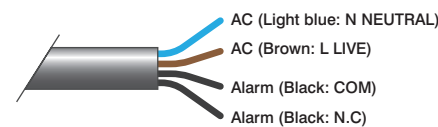

How to connect the lead wire of the safety switch

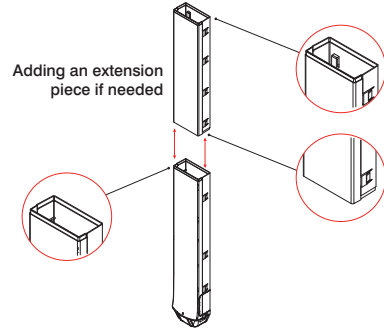
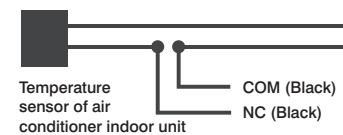

- Left and right hand install switching**

The pump is factory fitted for right hand installation. To adapt for left hand, unscrew the 4 screws on motor bracket and move to opposite side of the trunking.

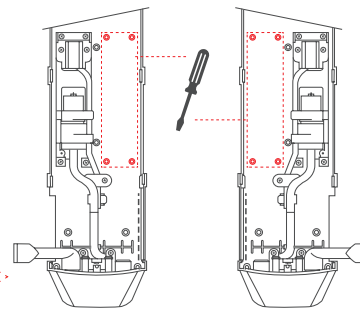

- Connect the power cable of the pump to the rated power. (Single phase 220V only).

Power should be continuously supplied to this equipment except when maintenance or follow-up service is carried out after installation of this equipment.

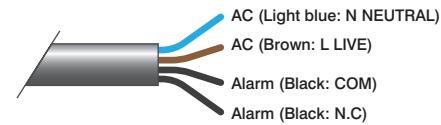

- Run the insulated refrigerant pipes through the knock out tabs and up the inside of the trunking, use cable ties as required to secure the pipe.

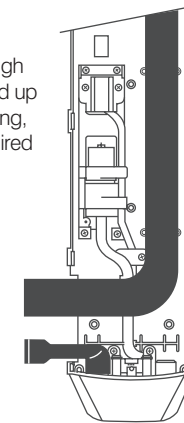

- Connect the discharge hose from the pump to an external drain.
 - Hose size is 1/4" (6mm) ID
 - Take care not to bend or kink the hose
 - Do not exceed the vertical lift limit of the pump, use a rule of thumb 3m horizontal = 1m vertical

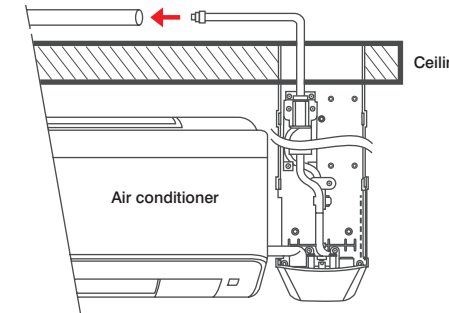

- Install the top cover of the trunking and fit the ceiling rosette if required.

After installing the top cover, press the length part of the side evenly so that both the top and bottom part of the case can be combined perfectly.

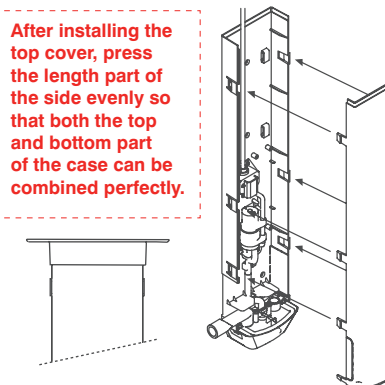

- Do a test run on your pump**

- Testing Pour a small amount of water into the drain pan of the A/C unit
- Watch the float rise and the pump should come of the 2 - 3 seconds pumping out the water from the reservoir. Repeat a few times to ensure all pump is working and check all pipe connections are secure
- Please note on first use the pump will be slightly noisier as air is expelled through the pump.

SAFETY PRECAUTIONS

- Do not use to pump flammable or explosive fluids such as gasoline, fuel oil, alcohol, etc.
- Do not use in explosive atmospheres.
- Do not use to pump hot water over 40°C.
- Do not handle pump with wet hands, or when standing on a wet or damp surface, or in water.
- To reduce the risk of electrical shock, be certain that the pump is connected to a properly grounded earth.
- Connect the pump only to the power supply specified on the name plate of the pump.
- If the power supply cord is damaged, it must be replaced by the manufacturer, or its service agent, or a similarly qualified person in order to avoid a hazard.
- The means for disconnection must be incorporated in the fixed wiring according to local wiring regulations.
- In any installations where property damage and/or personal injury might result in a non operational pump, a back up system and/or alarm should be used.
- Do not twist the drain or discharge hose.
- Before doing any maintenance or repair of the pump, please disconnect the pump from the power supply to avoid an electrical shock.
- Please note that the pump is not a submersible pump.
- Every installation or after-sales service, should be done by a qualified service technician.
- The intermittent ratings of this pump is not longer than 3 minutes.
- This pump is not designed to run dry. Repeated runs while dry will cause the pump to fail. This pump should not run for even a 1 minute period without fluid flowing through the pump.

SERVICE AND MAINTENANCE

- We advise service to be carried out at either the end of the summer season and in early spring to ensure A/C unit runs clean and the pump reservoir and pipework are clean and free from debris.
- Isolate the power to the pump and A/C unit
- Unclip the reservoir by pressing the tabs on either side and drop down. Be prepared to catch any remaining water in the system with a tray or towel to avoid spillage
- Wash the inside of the reservoir and wash the filter with clean water
- Remove the top cover of the trunking and remove the L shaped black hose connector and wash through.
- Ensure the drain hose of the A/C unit is also free from dirt and debris by washing through with clean water. Use a tube brush if stubborn debris is on the inside of the hose.
- Refit L shape hose connector, top part of pump trunking and replace the reservoir. If the float switch has been removed ensure the magnet part is at the top.
- Reconnect power supply and test pump by adding water to the drain pan of the A/C unit and ensure pump works correctly.

PUMPS
WHISPA-Q
Ultra Quiet Pump in Trunking

PUMP
HOUSE
DIVERSITECH
company