

UT336A

Refrigerant Leak Detector

User Manual



Preface

Thank you for purchasing the new UT336A refrigerant leak detector. In order to use this product safely and correctly, please read this manual thoroughly, especially the Safety Instructions part.

After reading this manual, it is recommended to keep the manual at an easily accessible place, preferably close to the device, for future reference.

Limited Warranty and Liability

Uni-Trend guarantees that the product is free from any defect in material and workmanship within one year from the purchase date. This warranty does not apply to damages caused by accident, negligence, misuse, modification, contamination or improper handling. The dealer shall not be entitled to give any other warranty on behalf of Uni-Trend. If you need warranty service within the warranty period, please contact your seller directly.

Uni-Trend will not be responsible for any special, incidental or subsequent damage or loss caused by using the device.

1. Introduction 4

2. Features 4

3. Configurations 4

4. Safety..... 4

5. Components & Buttons 5

 5.1 Components..... 5

 5.2 Buttons..... 6

6. Operations 6

 6.1 Basic Detection Flow..... 6

 6.2 Operating Details..... 7

 6.3 Detection Methods..... 7

 6.4 Cautions 8

7. Specifications 8

8. Applications..... 9

9. Troubleshooting..... 9

10. Maintenance 9

 10.1 General Maintenance 9

 10.2 Battery Installation & Replacement..... 10

1. Introduction

UT336A is a negative corona electronic refrigerant leak detector, features of rapid response, high-accuracy leak detection, high reliability, easy-to-use, and etc. It is widely used in refrigeration industries using refrigerant, such as the air conditioner maintenance, car maintenance, refrigeration unit detection, refrigerator maintenance, and etc.

2. Features

- ★ With high sensitivity, and minor leak can be detected.
- ★ Sensitivity adjustment in six levels, suitable for multiple scenarios with different leak concentration.
- ★ Audible and visual alarm in six levels, with intuitional indication of LED in yellow, orange and red.
- ★ Auto-reset when enable the device, and the current condition is set to zero.
- ★ Function of LED power indication.
- ★ Simple & Easy-to-use

3. Configurations

Refrigerant Leak Detector -----	1
Quick Start Guide -----	1
Safety Guideline -----	1
AA Alkaline Battery -----	4
Auxiliary Probe -----	1

Please contact agency if any components are missing or damaged.

4. Safety

Please read the Safety carefully and follow these steps.

 “Warning” identifies possible conditions and operations that are dangerous to the user.

“Caution” identifies some elements that can cause damage to the product or the device under test.



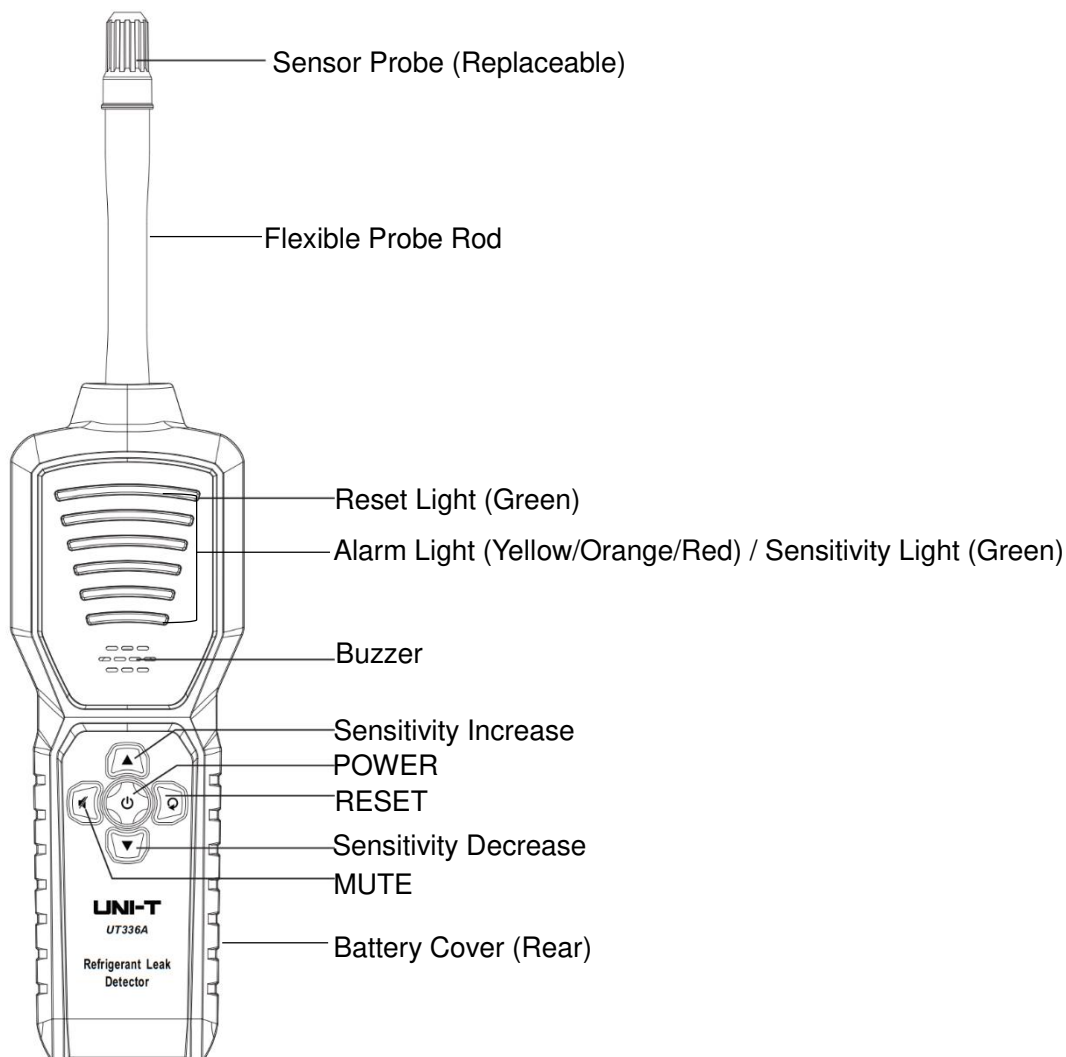

- Check the meter and accessories for any damage or abnormal phenomenon before using. Do not use the meter if the case is apparently damaged, or it is not working properly in any way.
- Do not open the meter randomly and change the internal wirings to avoid damage.
- Do not store or use the meter in high temperature, high humidity, flammable, explosive or strong electromagnetic environment.
- Use soft cloth and neutral detergent to clean the case. Do not use abrasives or solvent.
- Store the meter in a dry and clean place.
- Power off the device before replacing the probe to avoid the electric shock caused from the probe.

5. Components & Buttons

5.1 Components



5.2 Buttons





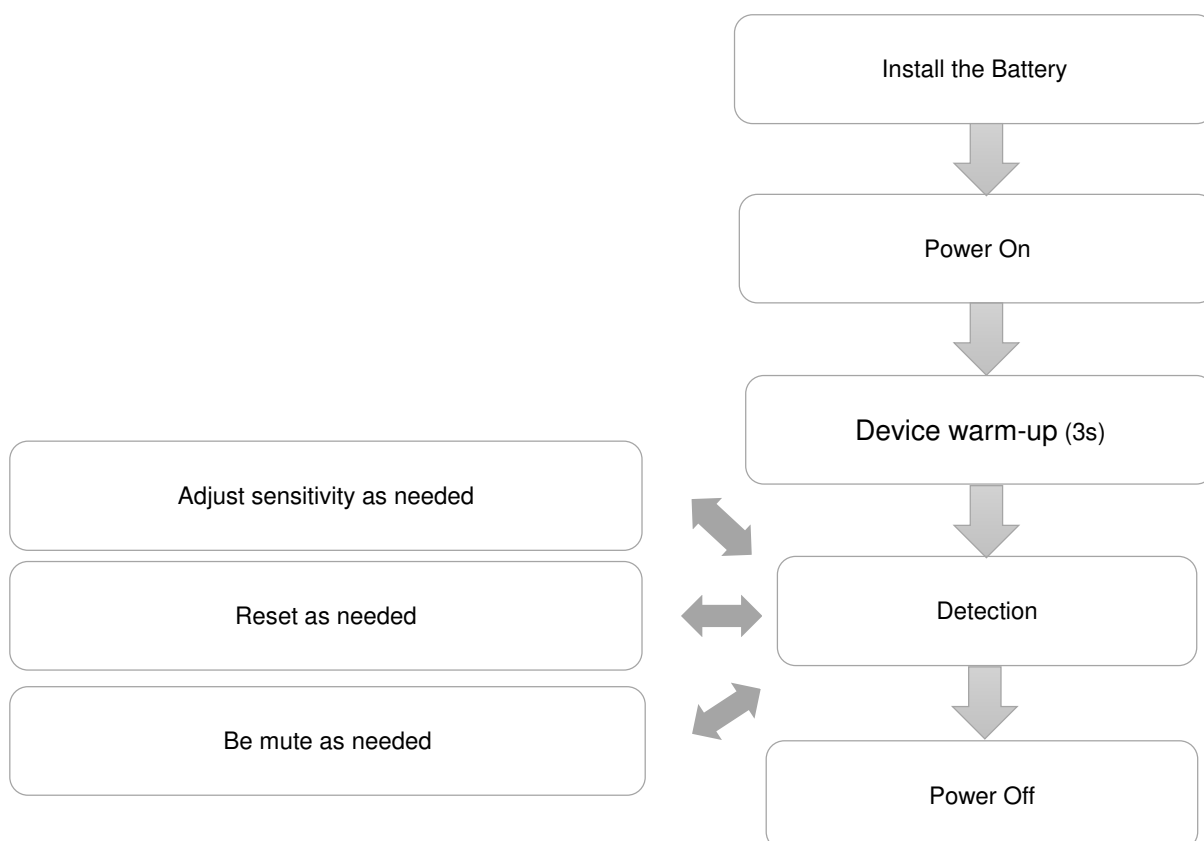

	Buttons	Short Press	Long Press	Lights
	Sensitivity Increase	The detection sensitivity is increased	/	Green light is on level by level
	POWER	/	Power on/off	Full battery: Backlight in Green Low battery: Backlight in Red Depleted battery: Flashing in Red
	RESET	Set the current gas concentration to zero	/	Green light is off after 2s on
	Sensitivity Decrease	The detection sensitivity is decreased	/	Green light is off level by level
	MUTE	Buzzer ON/OFF	/	/

6. Operations

6.1 Basic Detection Flow



6.2 Operating Details

- a) Power-on Self-detection: Long press POWER button , and six green lights are on level by level and then off (meanwhile with Di sound), followed by Yellow/Orange/Red light on then off. Reset as per the current gas condition, with regular Di sound in device, backlight of POWER button in green, finishing the power-on self-detection procedure to go on the normal detection.
- b) Detection: Hold the device to move probe to find the leak location in the pipeline and interface of refrigerating system. When the refrigerant is detected, there will be with Di sound increasing in frequency, and alarm lights in Yellow/Orange/Red are on level by level as per the leak concentration.
- c) Sensitivity Adjustment: The default sensitivity of device is level 3, and short press Sensitivity Increase button  or Sensitivity decrease button  to adjust the sensitivity as needed, six levels of green lights will also be adjusted as per the different sensitivity.
- d) Reset: Short press RESET button  to set the current gas concentration to zero, it will be alarming when high leak concentration is detected, and the reset green light will be off after 2s on during the reset. Short press the RESET button to set zero if it is alarming before the leak location is detected until no alarm (sound/light) shown to go on the detection process.
- e) Mute: Short press MUTE button  to turn on/off the buzzer as needed.
- f) Power Off: Long press POWER button  and six levels of green lights will be off level by level after on to shutoff the device.

6.3 Detection Methods

- a) Visually inspect the refrigerating system to check if any oil and dust on the pipeline, any leak on the connector, valve, maintenance port, copper welding spot or pipeline.
- b) Move the probe to carefully check every possible area, along the pipeline to check and avoid any potential leak missed. Mark it down and go on the detection when any leak area is detected.
- c) The speed of moving probe should be $\leq 1\text{cm/s}$ in the detection site, and the probe distance should be kept in 1-3mm. See followings:

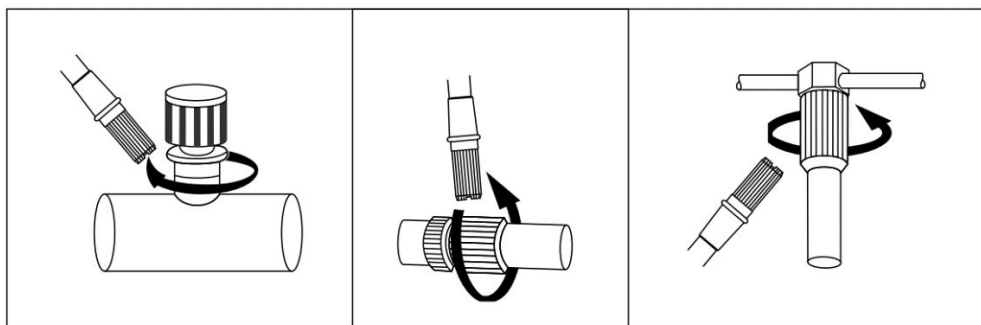

- d) ① Alarming of device identifies the approaching leak location, repeatedly detect the surroundings to check if any repeat alarm occurred.
- ② When the leak location is ensured, move the probe from different directions of non-alarm area to the alarm area to locate the leak source.
- ③ Move the device away from the leak area, then reset the device and gradually decrease

the sensitivity to repeatedly locate the concrete leak source.

- ④ Mark it down then go on the detection for other parts of the whole refrigerating system when the leak location is concreted.

Notes:

- The detection will also be effected by other pollutants, using dry cloth to cleanly wipe and dry air to blow the leak area before the redetection to avoid any inaccuracy, and then repeatedly detect to find the leak location.
- Following is for the obvious leak detection:
 Firstly, use compressed air to blow and clean the potential leak area, and repeatedly detect to locate the correct leak location. Secondly, move the probe to the environment with fresh and clean air to reset, then put the probe to the surrounding of leak location, moving probe slowly to locate the leak source.

6.4 Cautions

- a) Oil and dust is existed in most of leak conditions, we should prevent the probe from contacting any pollutants, any moisture or other solvents.
- b) If any halogen pollution is detected in the condition, ensure without leaving the polluted condition to use RESET button to ignore the leak halogen in the environment.
- c) It is suggested to use wind shields to isolate the detection site or shield the leak area to prevent the leak air from spreading or diluting during the detection.
- d) Check if the refrigerating system has its normal pressure during the leak detection, or the part of refrigerating system is at least 50PSI to avoid missing the leak detection due to the low pressure.

7. Specifications

Sensor	Negative Corona Sensor
Maximum Sensitivity	3g/a
Warm-Up Time	3s
Sensitivity Adjustment	6 Levels (Green light)
Alarm Light	6 Levels (Yellow/Orange/Red light)
Battery Status	Supported
Battery	AA Alkaline Battery *4
Battery Life	20h (Alkaline Battery)
Auto Power Off	Auto shutoff in 15 minutes if without any actions
Probe Life	About 50h in normal detection condition
Operating temperature and humidity	0°C-50°C, < 95%RH(non-condensing)
Size	190x65x43mm(Not probe rod included)
Weight	312g(Not battery included)

*EMC Standard: EN IEC 61326-1:2021

8. Applications

Three main types of halogenated (Chlorine & Fluorine included) refrigerants of the refrigerating system and containers can be detected by the device:

- CFCs R11, R12, R13, R14, R15, R500, R502.....
- HCFCs R22, R123, R141, R142.....
- HFCs R134a, R125, R32, R410A.....

9. Troubleshooting

Troubles	Reasons	Solutions
Fail to enable the device	Depleted battery	Replace the new battery
No response to the known leak source	Burn-in probe of sensor	Replace a new sensor probe
False alarm but no leak source	Humidity changed in the atmospheric condition	Press RESET button to reset to zero

- Replace a new one to ensure the high performance of probe after a long-time use. Probe life is related with the using frequency and using condition, so it is hard to estimate the replacing time of probe. It's time to replace a probe when it is alarming or unstable in the clean air.

⚠ Warning: Power off before replacing the probe to avoid the electric shock caused from the probe.

- a) Ensure the device is in OFF.
- b) Twist off the original probe in anti-clockwise direction and twist on the new installed one in clockwise direction

10. Maintenance

10.1 General Maintenance

- a) Pay attention to the probe cleaning to avoid any dust, moisture, oil into it.
- b) Use cotton cloth or dry gas to clean the outside of soiled probe. Soaking the probe in the pure alcohol for a few minutes if the probe itself is dirty, then use compressed gas to dry or cloth to wipe. Notes: Do not use strong dissolving agent to prevent the detector sensitivity inaccuracy, such as the Gasoline, Vaseline, Mineral oil, etc.
- c) Replace the battery in time when the red light of POWER button is on or flashing, ensuring the proper use and test results of the device.
- d) Store the device and probe in the dry and clean place.
- e) Remove battery when the device is not used for a long time.
- f) Maintenance and service must be implemented by qualified professionals or specified departments.

10.2 Battery Installation & Replacement

- a) Battery of 1.5 V *4 (AA), and see the followings for battery installation.
- b) Facing the panel of device down, open the battery cover to install new batteries as per the battery polarity.
- c) Close the battery cover.
- d) Please use the same type of battery.

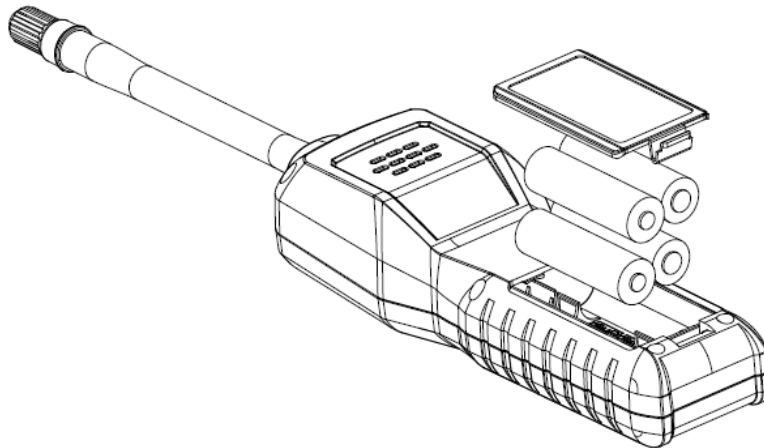

* The contents of this manual are subject to change without prior notice.

* Due to different batches, the materials and details of actual products may be slightly different from the graphic information, please refer to the actual product received. Experimental data provided in the page is from internal laboratory of UNI-T, but it should not be a reference for customer to place orders. Any questions, please contact the customer service, thanks!